

NOTES:

- 1 MODEL 5851LF, USES WASHER ITEM 10. ALL OTHER MODELS LISTED, USE WASHER ITEM 9.
- 2 WHEN RE-ASSEMBLING VALVE TIGHTEN DOWN ON (EXISTING) 3/8"-24 LOCK NUT UNTIL ACHIEVING A SLIGHT PLAY ON HANDLE. CAUTION: DO NOT OVER-TIGHTEN NUT. VALVE WILL LEAK.
- 3 LUBRICATE WITH GREASE BEFORE ASSEMBLY.
4. 5800VRKT CONSIST OF ITEMS 1 THRU 10 (ONLY). ALL OTHER COMPONENTS SHOWN (i.e. HANDLE, BODY, BONNET etc.) ARE FOR REFERENCE ONLY.

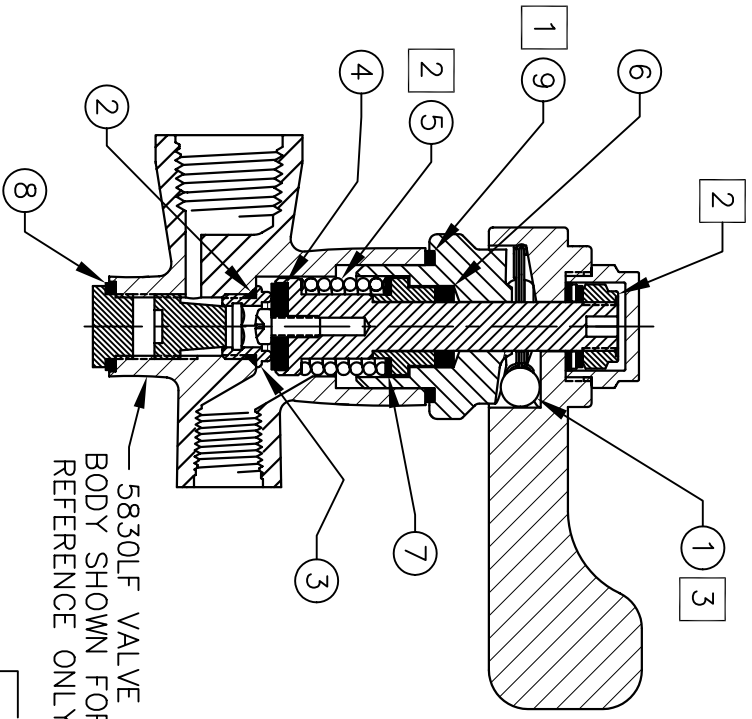

5830LF VALVE BODY SHOWN FOR REFERENCE ONLY

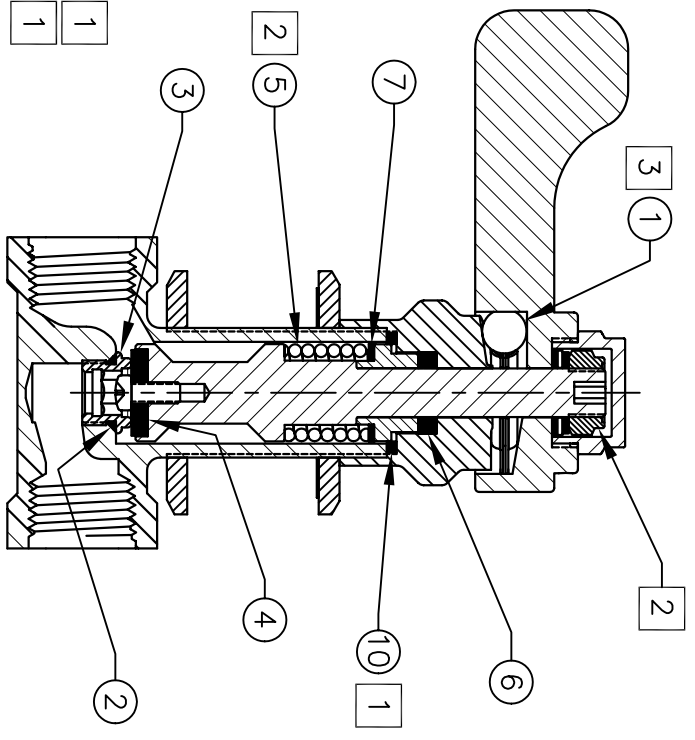
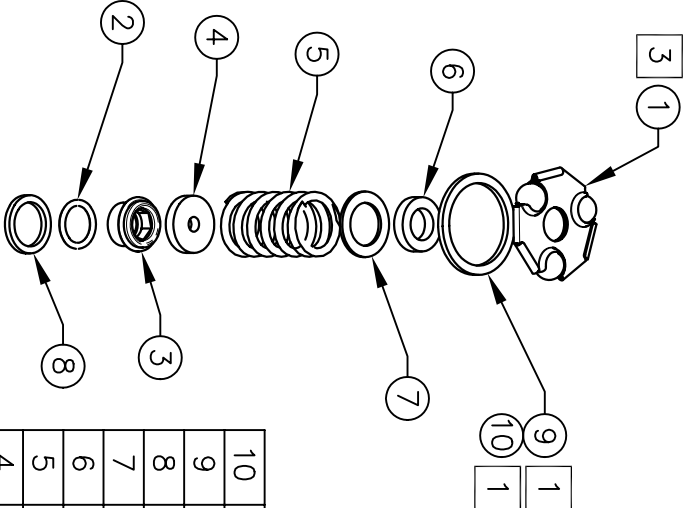

FOR MODEL:  
5851LF

FOR MODELS:

- 5830LF 5057LF 6252EHLF
- 5051LF 5060LF 5452LF
- 5054LF 6250LF 5054EG

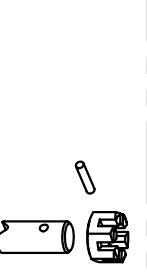

IF YOUR VALVE USES A CASTLE NUT WITH LOCK PIN TO SECURE THE HANDLE YOU MUST ORDER REPAIR KIT MODEL NO. 5800VRKR

ITEM	PART NO.	PART NUMBER
10	0006621020	WASHER, .923 X .751 X .075
9	0006634184	WASHER, 1.165 X .951 X .073
8	0006863494	WASHER, BTM CAP 5830
7	0006634380	WASHER, .75 X .494 X .04
6	0002582902	GLAND PACKING
5	0005425392	SPRING, .73 X 1.25 X 2.50mm
4	0006634576	WASHER, .660 X .170 X .125
3	0005208682	SEAT, 5830HST
2	0003981050	O-RING, .426 X .070 WALL
1	0000192993	BEARING SET

**Haws Corporation**  
 1455 Kleppe Ln, Sparks NV, 89431  
 Phone: 775-359-4712 Fax: 775-359-7424  
 Haws Ag Bachweg 3 CH-3401 Burgdorf Switzerland  
 Haws Mig Pte Ltd 74 Sungei Kadut Loop Singapore 729531  
 e-mail: Haws@hawsco.com website: www.hawsco.com

MODEL(S): 5800VRKT VALVE REPAIR KIT  
 INFO FAX DOC # 25800855  
 SCALE: N/A DRAWING TYPE: INSTALLATION/REPAIR

REV. 1  
 DRAWING NUMBER: 15226A00  
 PART NUMBER: 0002081896